

Experimental Investigation of Plastic Deformation Characteristics of Welded Carbon Steel Pipe Subject to Lateral Impact Loading

Matthew Rennie¹, Wijitha Senadeera^{1,2}

To Cite:

Rennie M, Senadeera W. Experimental Investigation of Plastic Deformation Characteristics of Welded Carbon Steel Pipe Subject to Lateral Impact Loading. *Indian Journal of Engineering*, 2021, 18(49), 79-87

Author Affiliation:

¹School of Chemistry Physics and Mechanical Engineering, QUT, Brisbane, QLD, 4000, Australia

²School of Mechanical and Electrical Engineering, University of Southern Queensland, QLD 4300, Australia; Email: wijitha.senadeera@usq.edu.au

✉Corresponding Author

Wijitha Senadeera, University of Southern Queensland, Springfield Campus, Springfield 4300, Australia, Phone: +61 7 3470 4086, e-mail: wijitha.senadeera@usq.edu.au

Peer-Review History

Received: 29 December 2020

Reviewed & Revised: 30/December/2020 to 02/February /2021

Accepted: 05 February 2021

Published: February 2021

Peer-review

External peer-review was done through double-blind method.

Publication License

This work is licensed under a Creative Commons Attribution 4.0 International License.



DISCOVERY
SCIENTIFIC SOCIETY

© 2021 Discovery Scientific Society. All Rights Reserved

ABSTRACT

Laterally loaded cylinders or pipes are common in many industrial applications. Of particular interest is the deformation response and ability to withstand impact loading due to collisions. The deformation and stress distribution of laterally loaded cylindrical shells is reasonably well established in the literature, however very few publications consider true dynamic loading. Hence, an experiment was conducted to determine the plastic deformation characteristics of welded carbon steel pipe subject to lateral impact loading. This report presents the results and establishes an empirical equation to determine the deformation for a given impact energy and specimen geometry. In addition, the acceleration characteristics are investigated and found to be constant, and therefore acceptable for use in impact attenuators. Moreover, the effects of weld seam placement are qualitatively considered and found to be insignificant in the energy absorption capability of the specimen. Established in the literature, however very few publications consider true dynamic loading. Hence, an experiment was conducted to determine the plastic deformation characteristics of welded carbon steel pipe subject to lateral impact loading. This report presents the results and establishes an empirical equation to determine the deformation for a given impact energy and specimen geometry. In addition, the acceleration characteristics are investigated and found to be constant, and therefore acceptable for use in impact attenuators. Moreover, the effects of weld seam placement are qualitatively considered and found to be insignificant in the energy absorption capability of the specimen.

Key words: Loading, collision, column, energy absorption, deformation

INTRODUCTION

The use of impact attenuation devices is becoming increasingly popular (Olabi, Morris and Hashmi 2007). Often these devices are expensive to develop and application specific, hence designers seek to find more cost-effective methods to produce robust designs that may be used for numerous applications. This report outlines the experimental procedure and develops an empirical relation

between the deformation and potential energy absorption of welded carbon steel pipe of various wall thickness and diameter subject to lateral (perpendicular to the axis of the pipe) impact load.

The significance of this experiment is to gain a better understanding of the deformation characteristics of a commonly used low cost product, to facilitate the development of a computational model. Welded carbon steel pipe is commonly used in piping networks for fluid transport applications. In many industrial applications these pipes are exposed to lateral impact loading causing them to deform. Therefore, understanding the deformation characteristics also has benefits in plant design.

BACKGROUND

Impact attenuation devices have widespread industry use. Many highly refined examples exist, for instance crumple zones in the automobile industry and roadside barriers.

From a first principals approach Faulkner established that an important characteristic of an impact attenuation device is to have a near constant or decaying rate of acceleration, as this results in the lowest average deceleration rate (Faulkner 1974). From this study it was established that there are four main concerns when considering the energy absorption of attenuation devices:

- Energy Conversion Ability
- Constant Reactive Force
- Stability and Repeatability
- Specific Energy Absorption Capacity.

The mechanisms by which impact attenuation occurs in deformation type devices is due to the plastic yielding of material (Chakrabarty 2010, Yu 2003, De Runtz and Hodge 1963). A review of the literature reveals that the study of laterally loaded cylinders is well established. De Runtz and Hodge (1963) investigated the lateral compression of circular steel tubes theoretically by approximating the geometry as four circular arcs coupled with stationary plastic hinges, along with a perfectly plastic material model. The results under-estimated experimental data, and attributed to strain hardening of material.

Redwood (1964) continued the works of DeRuntz and Hodge, by considering two plastic hinges that move radially outwards. In addition, the effects of strain hardening were accounted for by inclusion of a strain hardening modulus. This theoretical approach had improved results over the preceding study, however underestimated experimental data. Reddy (1979) and Reid (1964) further improved the model by incorporating plastic zones in the vicinity of the circular tube as well as the effects of side constraints.

Furthermore, Gupta (2005) and Hossenipour and Daneshi (2003), showed good experimental correlation between both aluminium and steel specimens with an FEA model generated using the FORGE2 code and found collapse was mainly attributed to the formation of multiple plastic zones along with elastic deformation of coupling curved tubular sections.

Many of the experimental procedures in the current literature involved quasi-static loading, hence the use of real-time dynamic loading and measurement is significant in itself (Zhu et al., 2010, Lu and Yu 2003).

EXPERIMENTAL PROCEDURE

Specimen geometries were developed to obtain a large spread of data. The resulting geometries based around commercially available products ranged from an outside diameter of 50 mm to 75 mm and wall thickness incrementally increasing from 1.2 mm to 3.3 mm. Where required, machining was carried out to alter the standard ASME pipe sizes (Sch. 40 – Sch. 60 stock). To restrain the specimen to the impact plates, a small tack weld was placed on the four corners as shown in Figure 1. The experimental procedure utilised a small-scale drop tower. The required height of the tower was based on preliminary estimations of the expected deformation of the weakest specimen geometry subjected to the dropped mass (4m drop height).

In order to capture the deformation data an IDT X-stream XS-4 512x512 high speed camera was used with the frame rate set to 1500 Hz (0.67 ms per frame) capture with a scale backing stage allowing for ± 0.5 mm accuracy. This was deemed adequate in relation to the error induced elsewhere in the experimental system and would provide sufficient resolution for the velocimetry algorithm developed to convert the visual length scale measurements. The experimental apparatus is shown in Figure .

Each specimen size was subject to an impact potential energy of half and full drop tower height in order to gain deformation characteristics in terms of both variations of potential energy and variation of geometry.

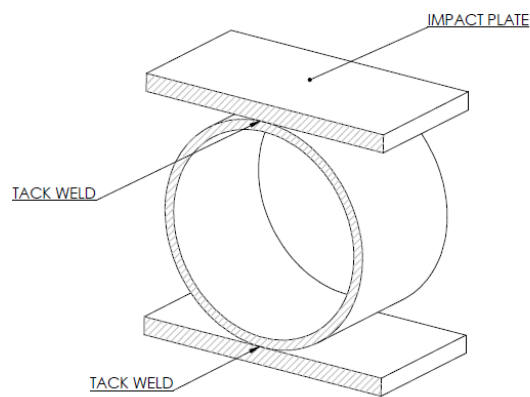

Figure 1 Specimen geometry and etainment tack weld location

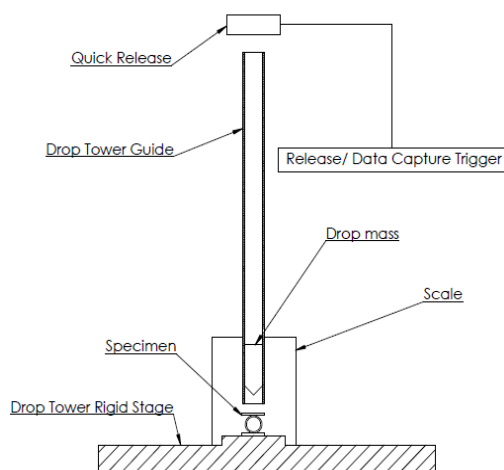

Figure 2 Experimental Apparatus

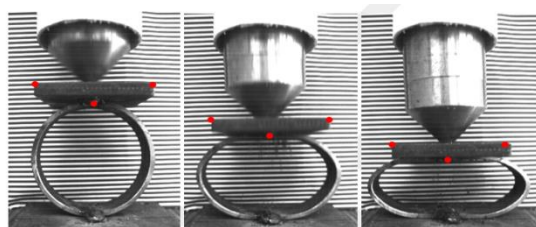

Figure 3 Example of pixel recognition and tracking using "trace points".

DATA ANALYSIS

As the clearance in the drop tower guide was larger than desired, there were concerns regarding the repeatability of the experiment due to the varying trajectory of the dropped mass. A comparison of the experimental specimens showed the experiment repeatability was high with each similar experiment showing the same total deformation within ± 1 mm. Figure 4 and Figure 5 show a number of test specimens from similar experiment settings. As can be seen the general shape of deformation is consistent. However, the thinner specimens suffered some distortion post experiment when being removed from impact plate. Interrogating

the high-speed camera data using a generic pixel tracking method, the frame rate and scale allowed the relative displacement between each frame to be determined and the displacement and velocity to be numerically scaled from the still images. The general procedure is shown in Equation 1. An example of the method showing exaggerated trace pixels is shown in Figure 3. The acceleration was determined by numerically differentiating the change in velocity.

$$V = (x_{n+1} - x_n) \cdot \frac{X}{\Delta t} \left[\frac{mm}{s} \right] \quad (1)$$

Where: x_n = pixel position at the n^{th} frame [pixels]

X = physical scale conversion $\left[\frac{mm}{pixels} \right]$, Δt = time per frame [s]

A dimensional analysis using the Buckingham Pi theorem, suggested that the deformation relation was dependant on the non-dimensional parameter of diameter to thickness ratio and deformation. A statistical analysis was conducted on the data that showed a similar trend with a high correlation between the deformation and the diameter to thickness ratio.



Figure 4 Complete deformation of 75 mm Test specimen, series increasing wall thickness from left to right, for 0.250 kJ potential energy dissipation, showing good repeatability of experiment



Figure 5 Complete Deformation of 50mm series test specimen for, increasing wall thickness from left to right, 0.25 kJ potential energy dissipation.

Using the relations set out in Equation 2 and 3, the following non-dimensional quantities where developed.

$$\frac{D}{t} = non - dimensional\ size \quad (2)$$

$$\frac{\delta}{D} \times 100 = Percent\ deformation \quad (3)$$

Manipulating the data around these quantities and plotting the experimental results showed two distinct trends, corresponding to the two energy impact quantities as shown in Figure 6. Also shown in the plot is the exponential line of best fits and the

correlating R2 value. As can be seen the R2 value is high suggesting an appropriate model. Starting with a generic equation of exponential form the following empirical relation was developed that predicts the percent deformation as a function of diameter and wall thickness ratio for a given energy absorption. The resulting equation is compared with the experimental data in Figure 7.

$$\frac{\delta}{D} = A \cdot Be^{(C \cdot \frac{D}{t})} \quad (4)$$

Where:

$$A = \frac{25}{L}$$

$$B = E(100(1 - E))$$

$$C = \frac{E(1-E)}{2.2+10E^{1.6}}$$

E = potential energy of Impact [kJ]

L = Length of Specimen [mm]

D = mean diameter [mm]

t = Wall thickness [mm]

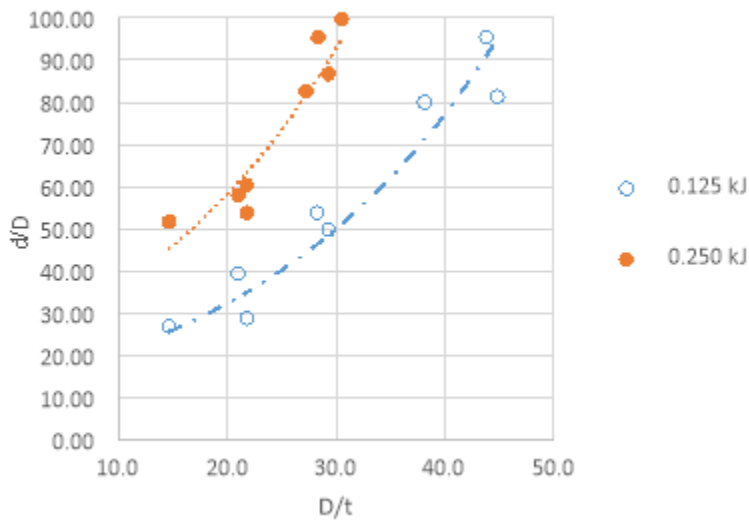

Figure 6 Experimental data for Percent deformation in response to non-dimensional size and Potential energy absorption

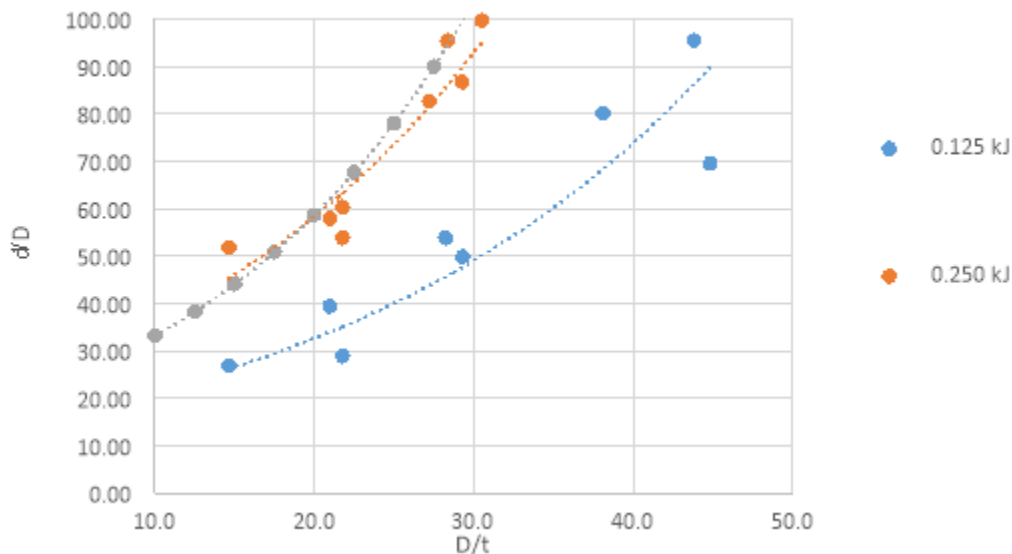

Figure 7 Comparison of Empirical Relation and Experimental data

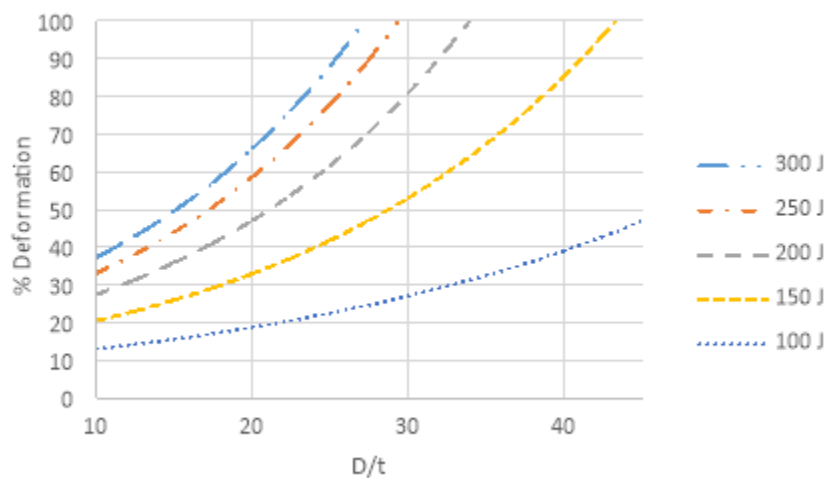
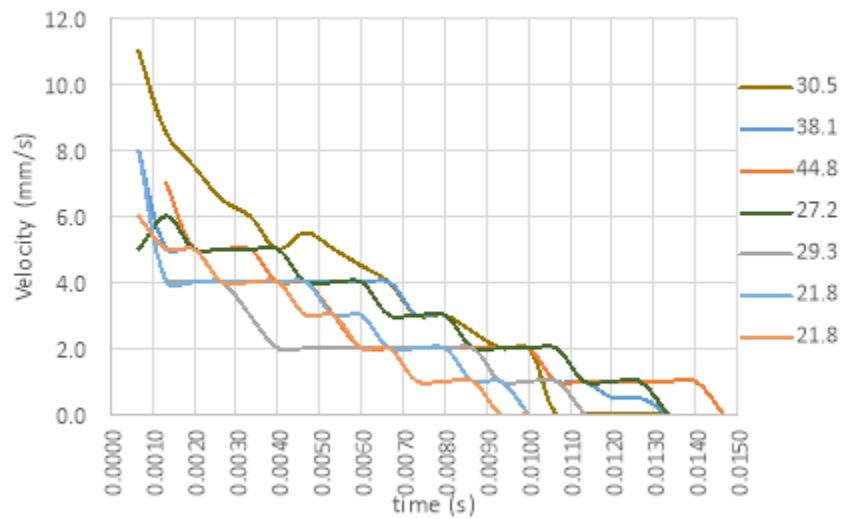

Figure 8 Design Chart developed from empirical relation, allowing the % Deformation to be determined given specimen geometry and potential impact absorption.

As can be seen from Figure 6, there is a definitive relation between the quantities. This allowed a generalised design chart to be developed that predicts the percent deformation when given specimen geometry and potential impact absorption. This type of chart is unique to this field of study. Should a designer require an impact attenuator to perform sufficiently without deforming substantially, the chart may be used as a guide to determine the required geometry. From Figure 7 it can be seen that the empirical model is conservative for higher potential energy of impact, and less conservative for lower potential energy of impact.

In addition to the deformation characteristics, the deceleration characteristics were investigated to determine the suitability of carbon steel welded pipe subject to lateral loading as an impact attenuator. Plotting the velocity as a function of time (Figure 9) for test specimens of varying diameter to thickness ratios, showed that the majority of test samples experienced a near linearly decaying velocity.

Velocity Response (75 mm Samples) For Varying D/t Ratio



Velocity Response (50 mm - Samples) For Varying D/t Ratio

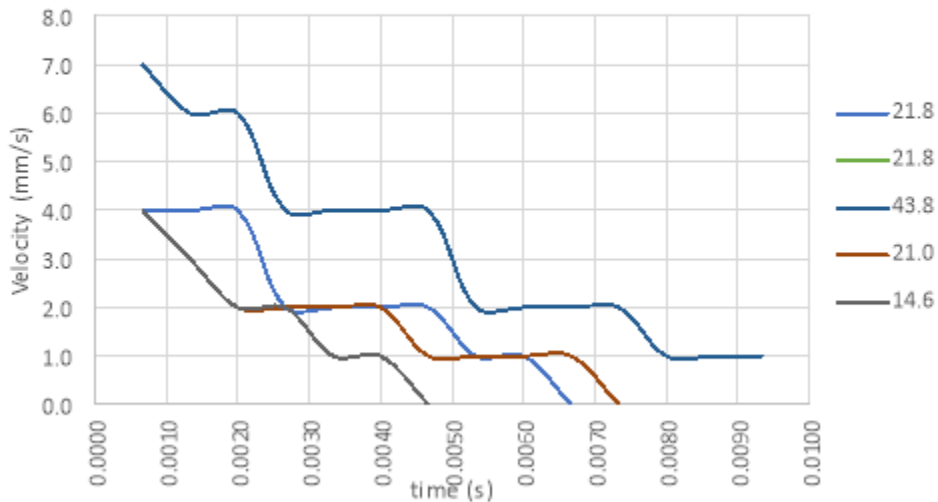

Figure 9 Velocity of specimen deformation for 17 test samples

Numerically differentiating the velocity plot with respect to time, allowed the acceleration to be determined. The results showed a near constant deceleration. Taking the average of all measurements shows that the average deceleration is:

$$a \approx \frac{\Delta v}{\Delta t} = \left(\frac{8}{0.01^2} \right) = 80\,000 \frac{mm}{s^2} = 80 \frac{m}{s^2} = 8.15\,g \tag{5}$$

The maximum average deceleration (corresponding to the 48 × 3.3 mm specimen) is:

$$a_{max} \approx \frac{4}{0.005^2} = 160\,000 \frac{mm}{s^2} = 160 \frac{m}{s^2} = 16.3\,g \tag{6}$$

The minimum average deceleration (corresponding to 76 × 2.8 mm specimen) is:

$$a_{max} \approx \frac{6}{0.015^2} = 26\,667 \frac{mm}{s^2} = 26 \frac{m}{s^2} = 2.6\,g \quad (7)$$

This result is expected since the smallest diameter and largest wall thickness results in a stiff cross section and hence high reactive force and acceleration. Whereas the least rigid cross section experienced low acceleration due to the low resistive force. As can be seen, the velocity decrease is on average linear, and hence a constant acceleration and constant reactive force. As mentioned previously these are desirable behaviours in impact attenuation devices.

One further interesting phenomenon that was investigated during the experiment was the location of the welded seam in relation to the deformation. As shown in Figure rotating the welded seam through 90 degrees showed to have little effect on the deformation and energy absorption characteristics. Furthermore, specimens that required machining (hence removal of the upper edge of weld bead) did not have drastically different deformation characteristics than those that did not.



Figure 10 Test Specimen with welded seam oriented at 0 degrees (left) and 90 degrees showing limited effect of seam placement on deformation.

Limitations

The form of Equation 4 suggests that plastic deformation and hence energy absorption occurs when the thickness becomes large. For example, when the specimen approaches a solid bar, it is expected that almost no plastic deformation occurs (excluding minor surface indentation). Figure 6 shows that the experimental data was not detailed in these high thickness specimens. As a consequence of this the design chart of Figure 8 is limited to the diameter to thickness ratios seen in the experimental data, and extrapolated between the two energy absorption levels.

In addition, the limited accuracy of the measurement equipment and pixel detection algorithm induces some error in the results. Other forms of error arise in the machining of samples and the slight lack of rigidity in the drop tower. A “no-specimen” test was conducted to investigate the effects of the stiffness of the rigid stage; however, results were inconclusive.

CONCLUSION

The experiment allowed a relation between the percent deformation, potential energy of impact and diameter to wall thickness ratio to be established. Furthermore, this allowed an empirical equation and design chart to be developed. The velocity and acceleration characteristics of carbon steel welded pipe subject to lateral impact load were investigated and deemed suitable based on the criteria set out by Falkner, for use as an impact attenuator. Furthermore, the effects of weld seam placement and machining were qualitatively discussed as having little effect on the deformation characteristics of carbon steel welded pipe. This experiment serves the purpose of allowing a better understanding of the dynamic behaviour of carbon steel welded pipe subject to lateral impact load and serves as a method for verification in future computational studies.

Acknowledgements

Authors acknowledge assistance of the Queensland University of Technology through their support for undergraduate thesis project. Mr Mark Hayne – QUT Technical Services, Practical Engineering Australia – Engineering Consultants and Troy Pannam – Lab Assistant.

Authors Contributions

Wijitha Senadeera: Mentoring the undergraduate student, suggested the project ideas and overall supervision of the project, manuscript preparation and editing

Matthew Rennie: Experimentation, data analysis, manuscript preparation and editing

Funding:

This study has not received any external funding.

Conflict of Interest:

The authors declare that there are no conflicts of interests.

Data and materials availability

All data associated with this study are present in the paper.

REFERENCES AND NOTES

1. Chakrabarty, J., *Applied Plasticity*, 2nd edition. New York: Springer: 2010.
2. De Runtz, J. A. and Hodge, P. G, *Crushing of tubes between Rigid Plates*, *Journal of Applied Mechanics*: 1963, 30(3), 391-395.
3. Faulkner, L. L., *Energy Absorption Devices*. Ohio State University Press: 1974.
4. Gupta, N. K., *Study of lateral compression of round metallic tubes*, *Thin walled structures*: 2005, 43(6), 895-922.
5. Hossenipour, S. J. and Daneshi, S. H. G. *Energy absorption and mean crushing load of thin walled grooved tubes under axial compression*, *Thin Walled Structures*: 2003, 41(1), 31-46.
6. Lu, G. and Yu, T. X., *Energy absorption of structures and Materials*, Woodhead Publishing Limited, Hongkong: 2003.
7. Olabi, A. G., Morris, E. and Hashmi, M. S. J., *Metallic tube type energy absorbers: A synopsis*, *Thin Walled Structures*: 2007, 45, 706-726.
8. Reddy, R., *Lateral Compression of Tubes and Tube Systems*, *International Journal of Mechanical Science*: 1979, 21, 187-199.
9. Redwood, R. G., *Discussion of Crushing of Tubes and Tube Systems*, *Journal of Applied Mechanics*: 1964, 21, 351-357.
10. Yu, G. L. A. *Energy Absorption of Structures and Materials*. Cambridge: CRC Press: 2003
11. Zhu, F., Lu, G., Ruan, D and Wong, Z. *Plastic deformation, Failure and Energy absorption of sandwich structures with metallic cellular cores*, *International Journal of Protective Structures*: 2010, 1(4), 507-541.