

Iris Recognition using Invariant Moment Features Based on Haar Wavelet Decomposition

Publication History

Received: 04 July 2015

Accepted: 01 August 2015

Published: 1 September 2015

Citation

Arjunan T, Thangavel K, Sasirekha K. Iris Recognition using Invariant Moment Features Based on Haar Wavelet Decomposition. *Indian Journal of Engineering*, 2015, 12(30), 54-59

Iris Recognition using Invariant Moment Features Based on Haar Wavelet Decomposition

T. Arjunan
Research Scholar
Department of Computer Science
Periyar University, Salem-636011
Tamilnadu, India.
arjunanmadhu@gmail.com

K. Thangavel
Professor
Department of Computer Science
Periyar University, Salem-636011
Tamilnadu, India.
drktvelu@yahoo.com

K. Sasirekha
Research Scholar
Department of Computer Science
Periyar University, Salem-636011
Tamilnadu, India.
ksasirekha7@gmail.com

Abstract—Biometric identification provides high level security by identifying individual based on the physiological and behavioral characteristics. Iris recognition can be considered as one of the most reliable and accurate method of biometric technology. The iris is an externally visible and protected organ whose unique pattern remains stable throughout adult life. The feature extraction plays a very important role in iris recognition system. In this paper, an iris recognition system based on invariant moment features is proposed. Initially, the iris portion is segmented from the original image using Circular Hough Transform and Canny Edge Detector. Then the segmented image is normalized using Daugman's Rubber Sheet Model. A set of seven invariant moment features are extracted from the normalized image after decomposition using Haar wavelet. These features are invariant to translation, rotation and scaling. Finally the matching process is carried out by comparing the input image with the template stored in the database using Euclidean distance. The performance of iris recognition is tested on Chinese Academy of Science Institute of Automation (CASIA) iris dataset.

Keywords—*biometrics; euclidean distance; haar wavelet; invariant Moment; iris recognition;*

I. INTRODUCTION

Iris recognition is a method of biometric authentication that uses pattern recognition techniques based on images of the irises of an individual's eyes. The authentication is based on the physiological or behavioural characteristics of human being. Among various biometric techniques such as (fingerprint, signature, face, palm-print, palm-vein, iris etc.) iris is found to be the most reliable and accurate trait for high secured applications. It is because iris is unique, stable, and non-invasive[1].

The iris recognition system consists of an automatic segmentation system that is based on the edge detector and is able to localize the circular iris and pupil region, occluding eyelids, eyelashes and reflections [2]. Features are extracted with different feature extraction methods to encode the unique pattern of the iris into biometric template. The Hamming distance was employed for classification of iris templates and two templates were found to match if hamming distance is greater than a specific threshold.

John Daugman, implemented a working automated iris recognition system [3]. The Daugman system is presented in [3]. Daugman's method, based on phase analysis, encodes the iris texture pattern into a 256 byte iris code by using some two dimensional Gabor filters, and taking the Hamming distance [3,4] to match the iris code.

Ma et al. [5] construct a bank of spatial filters whose kernels are suitable for use in iris recognition. They have also developed a preliminary Gaussian-Hermite moments-based method which uses local intensity variations of the iris [5]. They recently proposed an improved method based on characterizing key local variations [4].

Yu et al. [6] use box-counting method to estimate the fractal dimensions of the iris, then classify iris images into four categories in accordance with the fractal dimensions.

Lim et. al. [10] also used the wavelet transform to extract features from the iris region. Both the Gabor transform and the Haar wavelet are considered as the mother wavelet. From multi-dimensionally filtering, a feature vector with 87 dimensions is computed. Since each dimension has a real value ranging from -1.0 to +1.0, the feature vector is sign quantized so that any positive value is represented by 1 and negative value as 0. This results in a compact biometric template consisting of only 87 bits.

Hu. [18] derived six absolute orthogonal invariants and one skew orthogonal invariant based upon algebraic invariants, which are not only independent of position, size and orientation but also independent of parallel projection. The moment invariants have been proved to be the adequate measures for tracing image patterns regarding the images translation continuous functions and noise-free. Moment invariants have been extensively applied to image pattern recognition, image registration and image reconstruction [9].

In this proposed work a set of invariant moment features are extracted from the normalized image in wavelet domain. In section II, the iris image is denoised and normized. A set of invariant moment features are extracted from the normalized image in Section III. Section IV provides the experimental results of the proposed method. Section V concludes with some research perspectives.

II. IRIS IMAGE PREPROCESSING

The iris recognition system mainly consists of iris localization, normalization, feature extraction, and matching. Reprocessing of the iris image plays an important role in iris recognition system.

A. Localization

Iris localization is a process to isolate the iris region from the rest of the acquired image. Iris can be approximated by two circles, one for iris/sclera boundary and another for iris/pupil boundary. The pupil always lies in a dark area in the iris region [11].

Canny edge detection is used to generate an edge map. Then the circular Hough transform for the iris/sclera boundary is performed. From the above techniques all important parameters are calculated (radius and centre coordinates for both pupil and iris circles) [12].

After localizing an iris, the inner and outer boundaries are detected. In an eye image, the iris may be partially concealed by the upper eyelid, the lower eyelid, or the eyelash. Canny edge detector is applied to find the edges of the image and circular Hough transform is applied to the edge detected image to find the centre and radius of the iris using the equation (1).

$$(x-a)^2 + (y-b)^2 = r^2 \quad (1)$$

With

$$x = a + r \cos \theta \quad (2)$$

$$y = b + r \sin \theta \quad (3)$$

Where (a, b) is the centre of iris, (x, y) is the iris co-ordinate pixel and r is the radius of the iris [12].

B. Iris Normalization

As the size of an iris in a captured image always varies, the detected iris is normalized. The normalization is used to convert the Cartesian coordinate (x, y) to a polar coordinates [4,5]. Figure 1 shows normalization process.

The remapping of the iris region from (x, y) Cartesian coordinates to the normalized non-concentric polar representation is modeled as

$$I(x(r, \theta), y(r, \theta)) \rightarrow I(r, \theta) \quad (4)$$

With

$$x(r, \theta) = (1-r)x_p(\theta) + rx_l(\theta) \quad (5)$$

$$y(r, \theta) = (1-r)y_p(\theta) + ry_l(\theta) \quad (6)$$

Where $x_p(\theta), y_p(\theta)$ referred the pupillary boundary points and $x_l(\theta), y_l(\theta)$ denoted the limbic boundary points. The values of r lies in $[0,1]$ and θ locates in the range of $[0, 2\pi]$.

$I(x, y)$ is the iris region image, (x, y) are the original Cartesian coordinates, (r, θ) are the corresponding normalized polar coordinates, and (x_p, y_p) are the coordinates of the pupil and iris boundaries along the θ direction [6].

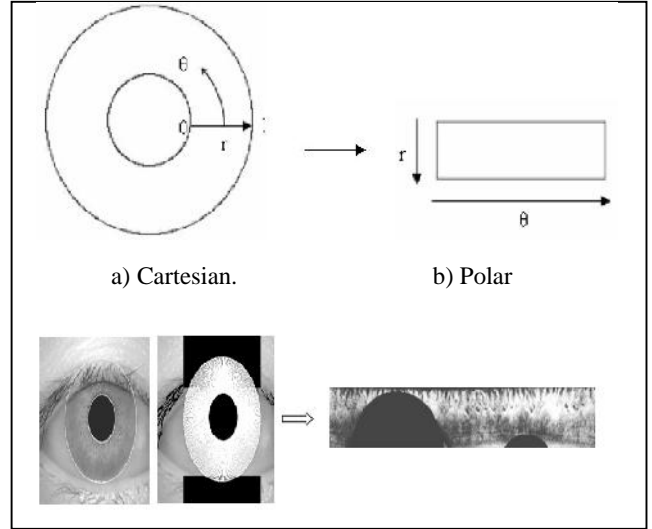

Fig. 1 Normalization Process

C. Iris Enhancement

The normalized iris image has low contrast and may have non uniform brightness caused by the position of light sources. All these may affect the subsequent processing in feature extraction and matching. In order to obtain a more well-distributed texture image, intensity variations across the whole image is approximated [10].

III. INVARIANT MOMENT FEATURE EXTRACTION IN WAVELET DOMAIN

A. Multilevel 2-D wavelet decomposition

The wavelet decomposition of the matrix X at level N , using the wavelet. Outputs are the decomposition vector C and the corresponding bookkeeping matrix S .

Vector C is organized as

$$C = [A(N) | H(N) | V(N) | D(N) | \dots \\ H(N-1) | V(N-1) | D(N-1) | \dots \\ | H(1) | V(1) | D(1)]. \quad (7)$$

where A, H, V, D , are row vectors such that

A = approximation coefficients

H = horizontal detail coefficients

V = vertical detail coefficients

D = diagonal detail coefficients

Each vector is the vector column- wise storage of a matrix.

Matrix S is such that

$S(1,:) = \text{size of approximation coefficients}(N)$.

$S(i,:) = \text{size of detail coefficients}(N-i+2)$

for $i = 2,3 \dots N+1$ and $S(N+2,:) = \text{size}(X) \dots$

For images, algorithm similar to the one-dimensional case is possible for two-dimensional wavelets and scaling functions obtained from one-dimensional ones by tensor product.

This kind of two-dimensional DWT leads to a decomposition of approximation coefficients at level j in four components the approximation at level $j+1$, and the details in three orientations (horizontal, vertical, and diagonal). The following chart describes the basic decomposition step for images.

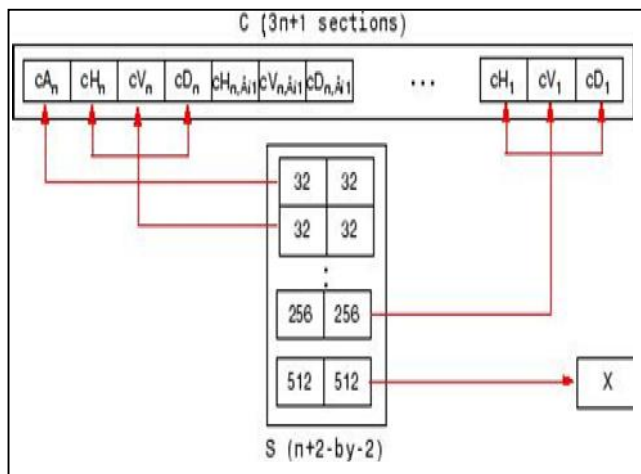

Fig. 2 Wavelet Decomposition

The Haar wavelet's mother wavelet function (t) can be described as (8).

$$\mathbb{E}(t) = \begin{cases} 1 & 0 \leq t < 1/2, \\ -1 & 1/2 \leq t < 1, \\ 0 & \text{otherwise} \end{cases} \quad (8)$$

and its scaling function (t) can be described as (9)

$$W(t) = \begin{cases} 1 & 0 \leq t < 1, \\ 0 & \text{otherwise.} \end{cases} \quad (9)$$

The Haar wavelet operates on data by calculating the sums and differences of adjacent elements. The Haar wavelet operates first on adjacent horizontal elements and then on adjacent vertical elements. The enhanced iris image is decomposed using Haar wavelet as in figure 2.

B. Hu's Invariant Moment

For a 2D continuous function $f(x,y)$ the moment of order $(p + q)$ is defined as

$$M_{pq} = \int_{-\infty}^{\infty} \int_{-\infty}^{\infty} x^p y^q f(x, y) dx dy \quad (10)$$

For $p, q = 0, 1, 2, \dots$ Adapting this to scalar (greyscale).

A uniqueness theorem in [15] states that if $f(x,y)$ is piecewise continuous and has nonzero values only in a finite part of the xy plane, moments of all orders exist, and the moment sequence (M_{pq}) is uniquely determined by $f(x,y)$. Conversely, (M_{pq}) uniquely determines $f(x,y)$. In practice, the image is summarized with functions of a few lower order moments.

Central moments are defined as

$$\tilde{m}_{pq} = \int_{-\infty}^{\infty} \int_{-\infty}^{\infty} (x - \bar{x})^p (y - \bar{y})^q f(x, y) dx dy \quad (11)$$

where $\bar{x} = \frac{M_{10}}{M_{00}}$ and $\bar{y} = \frac{M_{01}}{M_{00}}$ are the components of the centroid.

If $f(x, y)$ is a digital image, then (11) equation becomes,

$$\tilde{m}_{pq} = \sum_x \sum_y (x - \bar{x})^p (y - \bar{y})^q f(x, y) \quad (12)$$

The normalized central moments, denoted $y_{pq} = \frac{\tilde{m}_{pq}}{\tilde{m}_{00}^x}$, are defined as

Where $\chi = \frac{p+q}{2} + 1$ for $p+q=2, 3, \dots$

y_{20} = The abscissa variance

y_{02} = The ordinate variance

y_{11} = Covariance of ordinate and abscissa

y_{12} = Distribution intensity towards the right side compared to the left side of abscissa

y_{21} = Distribution intensity towards the upper side compared to the lower side in ordinate

y_{30} = The abscissa skew intensity

y_{03} = The ordinate skew intensity

Every one of the rotation invariant moments extracts a characteristic attribute of the image. For example I_1 represents the moment of inertia along the centroid while I_7 extracts skew invariant properties which are useful in differentiating between images which are mirror reflections of each other [16].

$$\begin{aligned}
I_1 &= y_{20} + y_{02}, \\
I_2 &= (y_{20} - y_{02})^2 + 4y_{11}^2, \\
I_3 &= (y_{30} - 3y_{12})^2 + (3y_{21} - y_{03})^2, \\
I_4 &= (y_{30} + 3y_{12})^2 + (y_{21} + y_{03})^2, \\
I_5 &= (3y_{30} - y_{12})(y_{30} + y_{12})[(y_{30} + y_{12})^2 \\
&\quad - 3(y_{21} + y_{03})^2 + (3y_{21} - y_{03}) \\
&\quad (y_{21} + y_{03})^2], \\
I_6 &= (y_{20} - y_{02})[(y_{30} + y_{12})^2 - (y_{21} + y_{03})^2] \\
&\quad + 4y_{11}(y_{30} + y_{12})(y_{21} + y_{03}), \\
I_7 &= (3y_{21} - y_{03})(y_{30} + y_{12}) \\
&\quad [(y_{30} + y_{12})^2 - 3(y_{21} + y_{03})^2] \\
&\quad - (3y_{21} - y_{03})^2 - (y_{30} + 3y_{12})(y_{21} + y_{03}) \\
&\quad [3y_{30} + y_{12})^2 - (y_{21} + y_{03})^2],
\end{aligned} \tag{13}$$

A set of seven invariant moments are extracted from the decomposed image[16].

C. Matching

Matching the templates is the last process in the iris recognition system. The Euclidian Distance is the most common technique used to recognize the iris. The features of the sample iris are compared with the template feature vector of the irises. The Euclidian Distance is measured using the following equation (14).

$$d_e^i = \sqrt{\sum_i^p (x_i - y_i)^2} \tag{14}$$

where the p is the dimension of the feature vector, x_i is the i th component of the sample feature vector, y_i is the i th component of the template feature vector.

IV. EXPERIMENTAL RESULTS

The Chinese Academy of Sciences Institute of Automation (CASIA) eye image database [10] contains 756 greyscale eye images with 108 unique eyes or classes and 7 different images of each unique eye. Images from each class are taken from two sessions with one month interval between sessions. The images were captured especially for iris recognition research using specialised digital optics developed by the National Laboratory of Pattern Recognition, China.

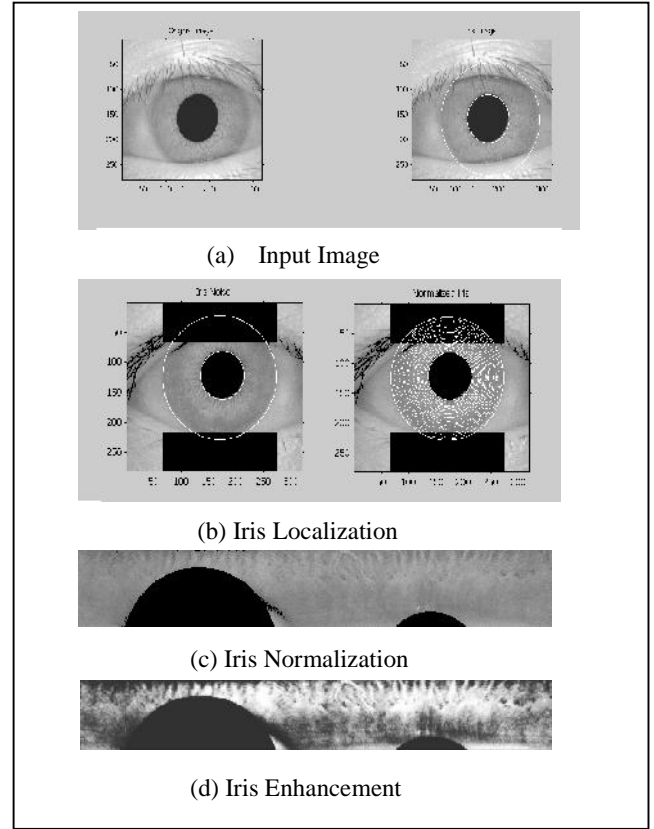

Fig. 3 Iris Recognition Process

The resulted similarity value is compared to the threshold level, if the similarity value is greater than or equal to threshold level the person is matched (authorized), otherwise the person is a mismatch (unauthorized). The Euclidean distance is used as a similarity measure for matching purpose, maximum accuracy of almost 100 % is obtained compared with Gabor filter based method. The results are shown in table1.

Table 1. Performances of the proposed method

Methodology		Recognition rate
Existing Method	GABOR, HD (11)	99.25 %
Proposed Method	INVARIANT MOMENT BASED ON WAVEDEC,ED	100 %

Fig. 4 shows the overall recognition process of iris image. Tests are carried out to confirm that iris recognition perform accurately as a biometric for recognition of individuals. Experiments are also conducted in order to confirm the uniqueness of human iris patterns on CASIA dataset.

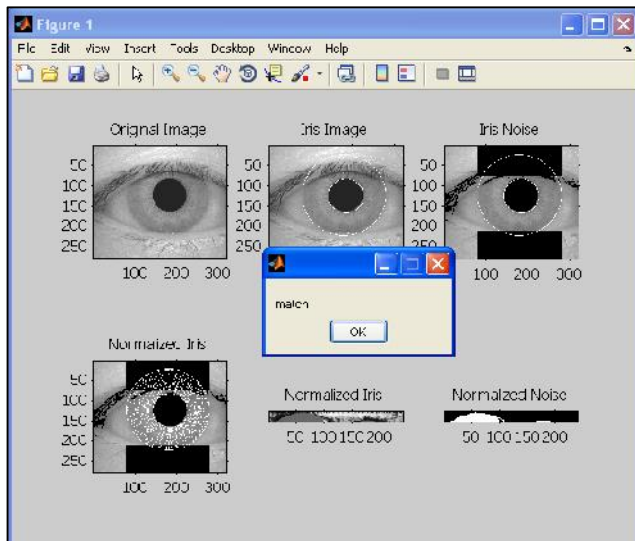

Fig 4. Recognition Result for User Iris Image

V. CONCLUSION

Iris recognition is one of the most reliable methods available today in biometrics field. In this paper, a novel feature extraction method based on invariant moment features in wavelet domain is proposed. The normalized iris image is decomposed using Haar wavelet. Since the feature extraction plays a very important role in iris recognition system, a set of seven invariant moments that are invariant to translation, rotation and scaling is extracted. Euclidean distance is used to compare the input image with template stored in the database. The accuracy achieved by the system is very good. CASIA dataset is used for testing the proposed method.

REFERENCES

- [1] R. Maini And H. Aggarwal, "Study and comparison of various image edge detection techniques", International Journal Image Process, pp. 1-11, 2009.
- [2] Sunita V. Dhavale, "DWT and DCT based Robust Iris Feature Extraction and Recognition Algorithm for Biometric Personal Identification", International Journal of Computer Applications, vol .40 Number 7, 2012.
- [3] J. Daugman, "How iris recognition works" In: IEEE Trans Circuits Syst Video Technol 14 1, pp. 21-30, 2004.

- [4] J. Daugman, "High confidence visual recognition of persons by atest of statistical independence" ,International IEEE Trans. Pattern Anal. Mach. Intell. 15 11, pp. 1148-1161 ,1993.
- [5] R.P. Wildes, "Iris recognition: an emerging biometric technology" In: Proceedings of the IEEE, vol. 85, no. 9, pp. 1348-1363 ,1997.
- [6] L. Ma, Y. Wang And T. Tan, "Iris recognition using circular symmetric filters". In, Proceedings of the 16th international conference on Pattern recognition, vol. 2, pp. 414-417 ,2002.
- [7] T. Lee, "Image representation using 2D Gabor wavelets" In: IEEE Trans. Pattern Anal. Mach. Intell. 18 10, pp. 959-971 ,1996.
- [8] W. K. Kong, D. Zhang, "Accurate iris segmentation based on novel reflection and eyelash detection model". In, Proceedings of the 2001 international symposium on intelligent multimedia, video and speech processing, pp. 263-266 ,2001.
- [9] Y. Zhu, T. Tan, And Y. Wang, "Biometric personal identification based on iris patterns". In: Proceedings of the 15th international conference on pattern recognition, vol. 2, pp. 801-804, 2000.
- [10] S. Lim, K. Lee, O. Byeon And T. Kim, "Efficient iris recognition through improvement of feature vector and classifier. ETRI J. Elect. Telecommun. Res. Korea 23, pp. 61-70 ,2001.
- [11] N. Ritter, R. Owens, J. Cooper, And P.P. VanSaarloos, " Location of the pupil-iris border in slit-lamp images of the cornea". In, Proceedings of international conference on image analysis and processing, pp. 740-745, 1999.
- [12] Iris database CASIA-IrisV3, Chinese Academy of Sciences Institute of Automation. Retrieved on Dec 2011. <http://www.cbsr.ia.ac.cn/IrisDatabase.html>.
- [13] J. Canny, "A computational approach to edge detection", IEEE Trans. Pattern Anal. Mach. Intell. PAMI-8, no. 6, pp. 679-698, 1986.
- [14] R.O. Duda And P.E. Hart, "Use of the Hough transform to detect lines and curves in pictures" ,Commun. ACM 15, pp. 11-15 ,1972.
- [15] J. Flusser, T. Suk, and B. Zitová, "Moments and Moment Invariants in Pattern Recognition", John Wiley & Sons, Chichester, UK, 2009.
- [16] S. O. Belkasim, M. Shridhar, and M. Ahmadi, "Pattern recognition with moment invariants: a comparative study and new results," Pattern Recognition, vol. 24, no. 12, pp. 1117-1138, 1991.
- [17] Christel Lolic Tisse, Lionel Martin, And Lionel Torres, "Person identification technique using human iris recognition", Proc. Of Vision Interface conference vol. 4, 2012.
- [18] M. K. Hu, "Visual pattern recognition by moment invariants," IRE Transactions on Information Theory, vol. 8, no. 2, pp. 179-187, 1962.